

Descrizione / Codice Description / Code	HPTDSE	HPTDSE S	HPTDSE V	HPTDSE VS	HPTDSE VOUT	HPTDSE VSOUT	HPTDSE DCC	HPTDSE DCC S	HPTDSE DCC VOUT	HPTDSE DCC VSOUT	Taratura valvola di massima pressione - Relief valve setting min - max (bar)
Soffietto Bellows S		X		X		X		X		X	30 - 250
Distributore 4/3 centro aperto Open centre 4/3 diverter	X	X	X	X	X	X					Comunque non oltre la pressione massima della pompa - However not over the pump's max pressure
Distributore 4/3 centro chiuso Closed centre 4/3 diverter DCC							X	X	X	X	
Valvola di massima pressione integrata al distributore Pressure relief valve inside diverter V			X	X							
Valvola di massima pressione esterna Outside pressure relief valve VOUT					X	X			X	X	
Foro di scarico - Discharging hole (E)	X	X	X	X	X	X	X	X	X	X	
Foro di scarico - Discharging hole (F)					X	X			X	X	
Y (mm)	36	36	36	36	59	59	36	36	59	59	

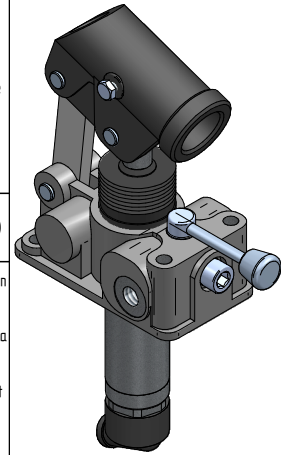

Montaggio: Qualsiasi posizione
Mounting: Any position

Fori di scarico - Discharging holes

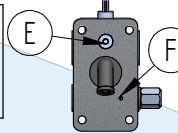

Valvola di massima pressione esterna - Outside pressure relief valve

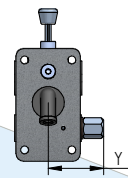

Kit di montaggio al serbatoio al - Mounting kit to oil tank

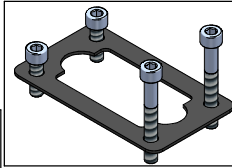

Valvola di massima pressione integrata al distributore - Pressure relief valve inside diverter

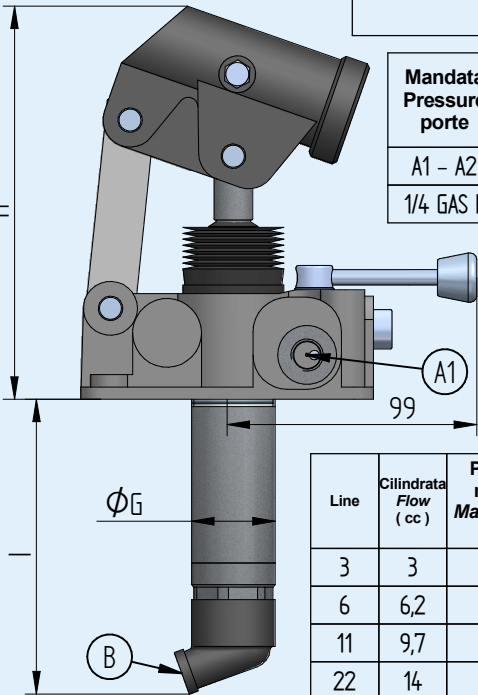
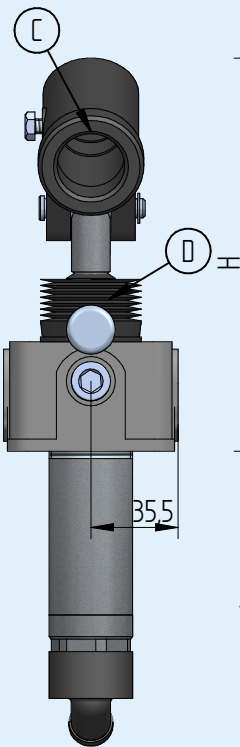
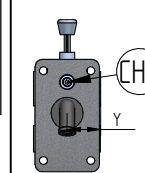

Mandata Pressure porte	Aspirazione Suction	Diametro interno porta leva Lever connection inside diameter	Soffietto Bellows
A1 - A2	B	C	D
1/4 GAS F		27 mm	

N°4 FORI Ø8,5 mm
N°4 HOLES Ø8,5 mm

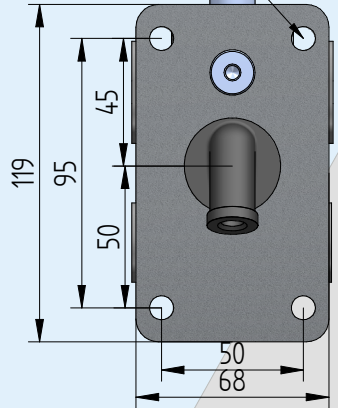

Line	Cilindrata Flow (cc)	Pressione massima Max pressure (bar)	Peso Weight (Kg)	H (mm)	I (mm)	G (mm)
3	3	250	3,1	145	100	34
6	6,2	250	3,0	145	95	34
11	9,7	250	3,1	145	108	34
22	14	250	3,2	148	114	38

03 ---
06 ---
11 ---
22 ---

Diagramma prove di carico
Load curve

