

Code	Cilindrata Flow (cc)	Pressione massima Max pressure (bar)	Peso Weight (Kg)
ALHPT06V	6	220	2,9
ALHPT12V	12,5	220	2,9
ALHPT25V	19,4	220	2,9
ALHPT45V	28	220	2,9

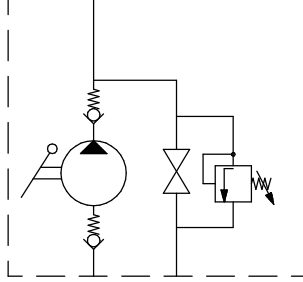

Mandata Pressure porte	Aspirazione Suction
A	B
3/8 GAS F	1/4 GAS F
Diametro interno porta leva Lever connection inside diameter	
C	
27 mm	

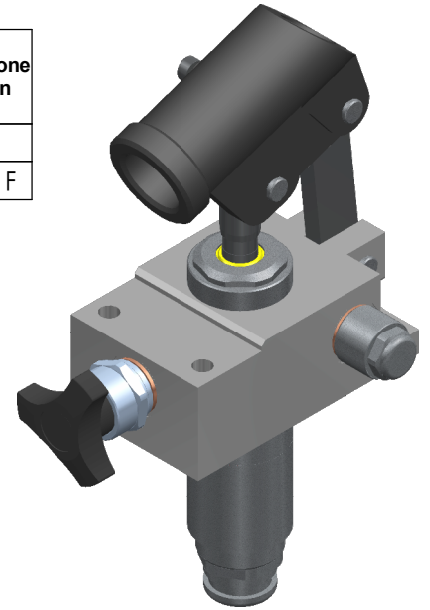

Taratura valvola di massima pressione - Comunque non oltre la pressione massima della pompa.
Relief valve setting - However not over the pump's max pressure
min - max (bar) 30 - 220



Diagramma prove di carico
Load curve



Montaggio: Qualsiasi posizione
Mounting: Any position

Kit di montaggio al serbatoio
Mounting kit to oil tank

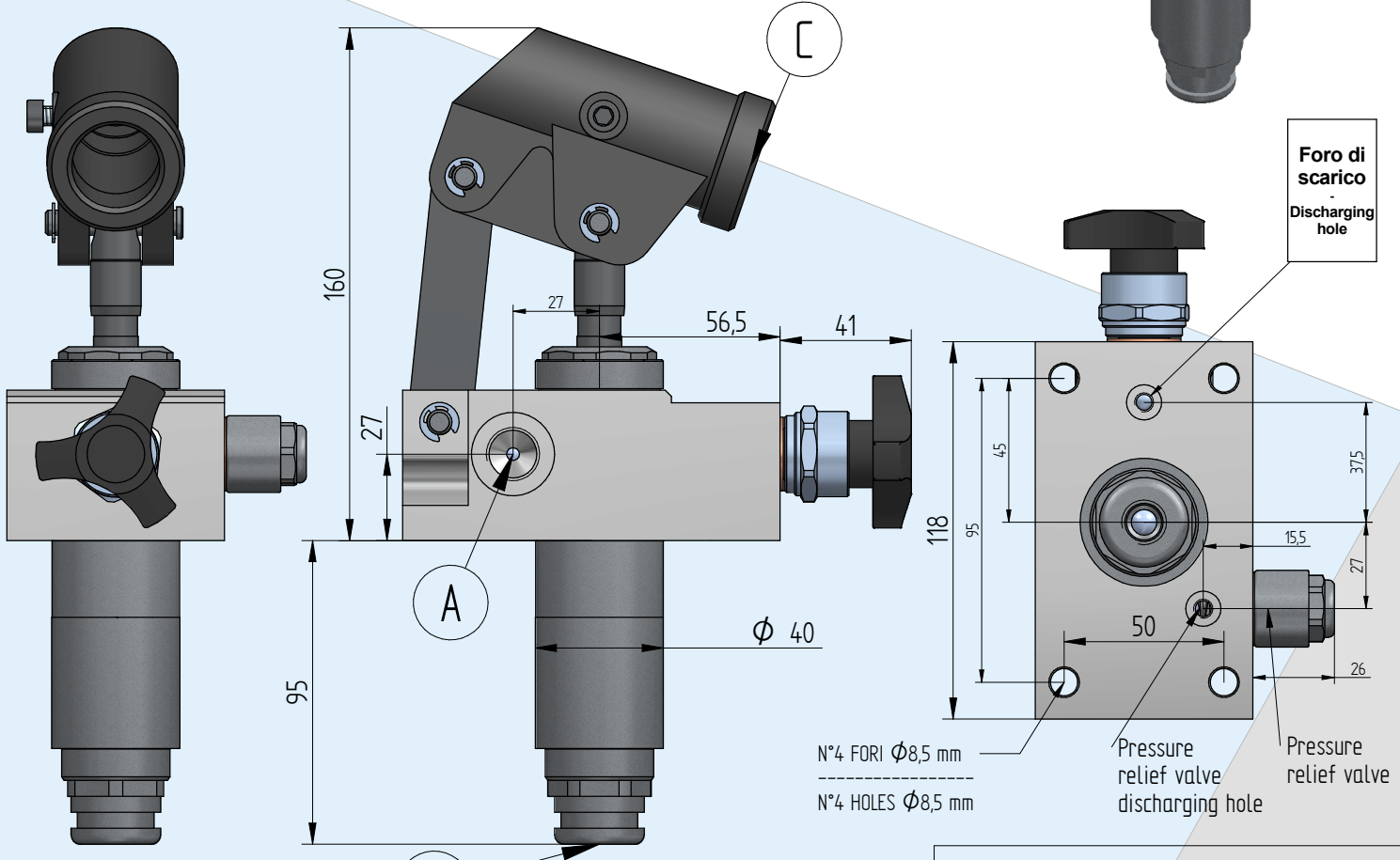
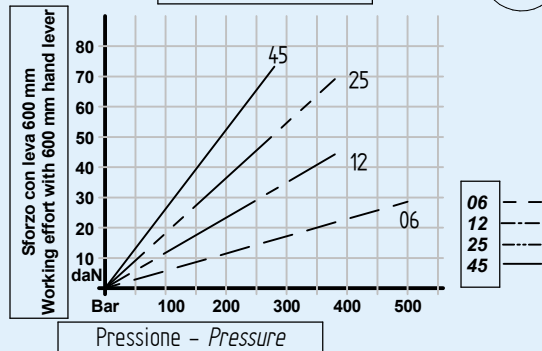
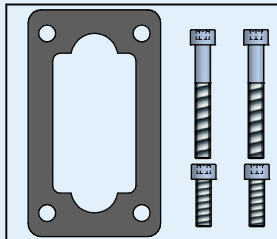

KFIL - Kfill - KFils

Filtro per aspirazione ordinabile separatamente
Suction filter can be ordered separately

