

Descrizione Description	VBDDO -G3/8	
Pressione massima - Max pressure	Bar	320
Portata - Flow	Lt/min	35
Peso - Weight	Kg	0,70
V1 - V2	3/8 GAS	
C1	Ø 12	
C2	Ø 16,8	
D	147	
E	116	
F	13	
G	67	
H	40	
I	30	
L	35	
Hex. CH	22	
O (on request)	Ø 6,5	
Rapporto pilotaggio - Pilot ratio	1:4	
Materiale corpo - Body material	Acciaio galvanizzato - Galvanized steel	

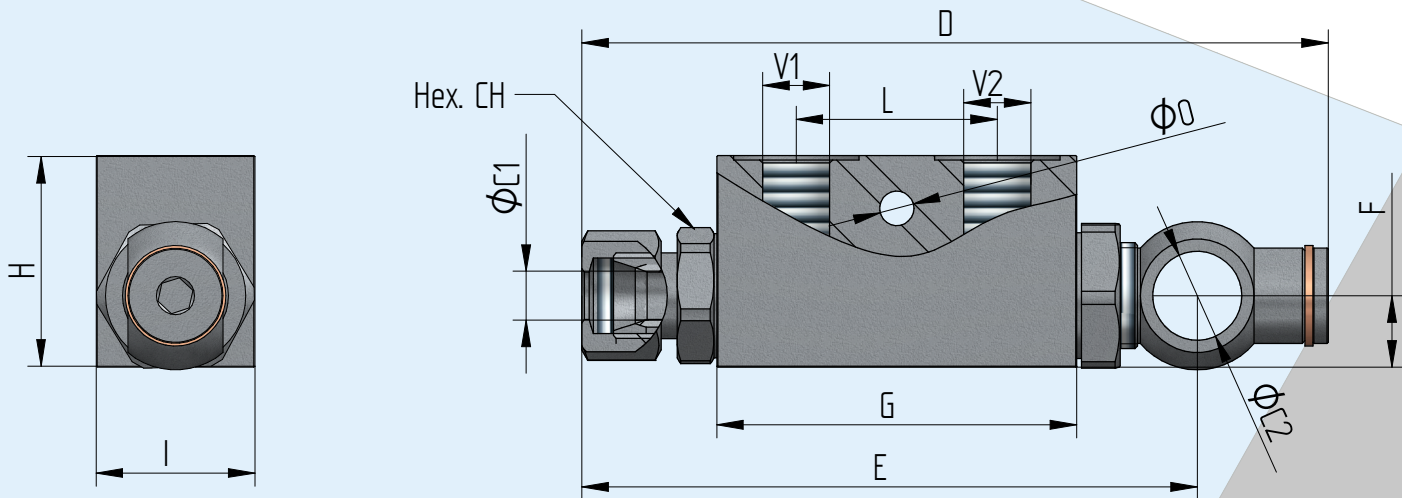
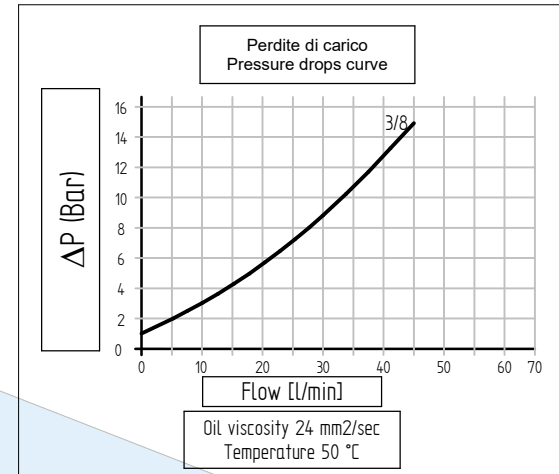
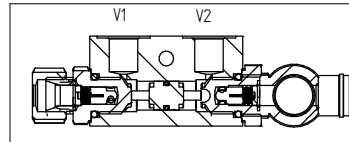
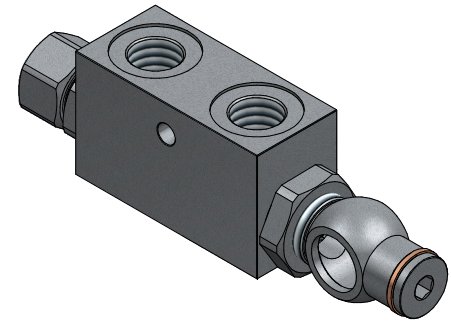
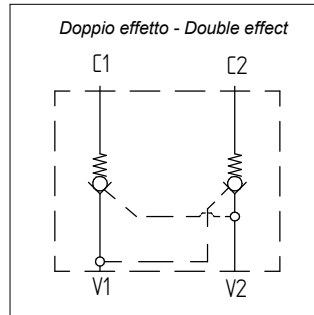

Codice di ordinazione Ordering code

VBDDO -	Option 1 G3/8	Option 2 M N	Option 3 X
---------	-------------------------	--------------------	---------------

Nel caso non si indicasse l'Opzione2 e/o l'Opzione3, sarà fornita in configurazione standard.

If Option2 and/or Option3 are not indicated, standard configuration will be considered.

Option 1	
Thread V1 - V2	
G3/8	Filetto 3/8 Gas Thread 3/8 Gas

Option 2	*= standard
M (*)	O-Ring su pistone pilota With seal on pilot piston
N	Senza O-Ring su pistone pilota Without seal on pilot piston

Option 3	*= standard
X (*)	Pressione di apertura Cracking pressure 1 Bar