

Descrizione Description	AI316VU -G1/4 MM	AI316VU -G3/8 MM	AI316VU -G1/2 MM	AI316VU -G3/4 MM	AI316VU -G1" MM	AI316VU -G1"1/4 MM	AI316VU -G1"1/2 MM	AI316VU -G2" MM
Pressione massima - Max pressure Bar	350	350	350	350	320	320	320	320
Portata - Flow Lt/min	8	20	50	90	90	250	300	650
Peso - Weight Kg	0,033	0,053	0,092	0,142	0,288	0,594	0,910	1,800
1 - 2	1/4 GAS	3/8 GAS	1/2 GAS	3/4 GAS	1" GAS	1" 1/4 GAS	1" 1/2 GAS	2" GAS
L	32	34	39	45	55	70	86	102
CH	19	22	27	32	40	50	55	70
Materiale corpo - Body material	Stainless steel AISI316							

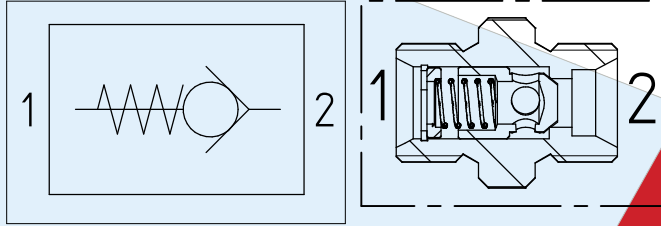
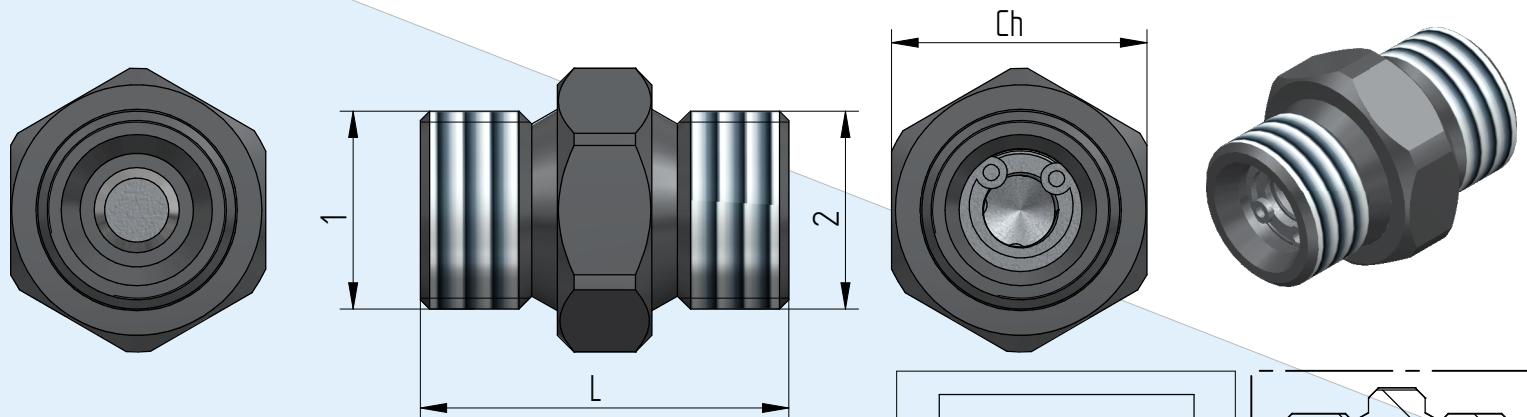

Codice di ordinazione
Ordering code

AI316VU-	Option 1	G1/4	MM	Option 2	X
		G3/8			Y
		G1/2			Z
		G3/4			
		G1			
		G11/4			
		G11/2			
		G2			

Nel caso non si indicasse l'Opzione2, sarà fornita in configurazione standard.
If Option2 is not indicated, standard configuration will be considered.

Option 1	Option 2	*= standard
Thread A1 - A2		
G1/4 Filetto 1/4 Gas - Thread 1/4 Gas	X (*)	Pressione di apertura Cracking pressure 1 Bar
G3/8 Filetto 3/8 Gas - Thread 3/8 Gas	Y	Pressione di apertura Cracking pressure Until 1" - 3 Bar From 1"1/4 - 6 Bar
G1/2 Filetto 1/2 Gas - Thread 1/2 Gas		
G3/4 Filetto 3/4 Gas - Thread 3/4 Gas	Z	Pressione di apertura Cracking pressure Until 1" - 6 Bar From 1"1/4 - 9 Bar
G1 Filetto 1" Gas - Thread 1" Gas		
G11/4 Filetto 1"1/4 Gas - Thread 1"1/4 Gas		
G11/2 Filetto 1"1/2 Gas - Thread 1"1/2 Gas		
G2 Filetto 2" Gas - Thread 2" Gas		

