

For single acting cylinder
without oil tank

Clockwise rotation
Rotazione oraria

For single acting cylinder
Per cilindro a semplice effetto

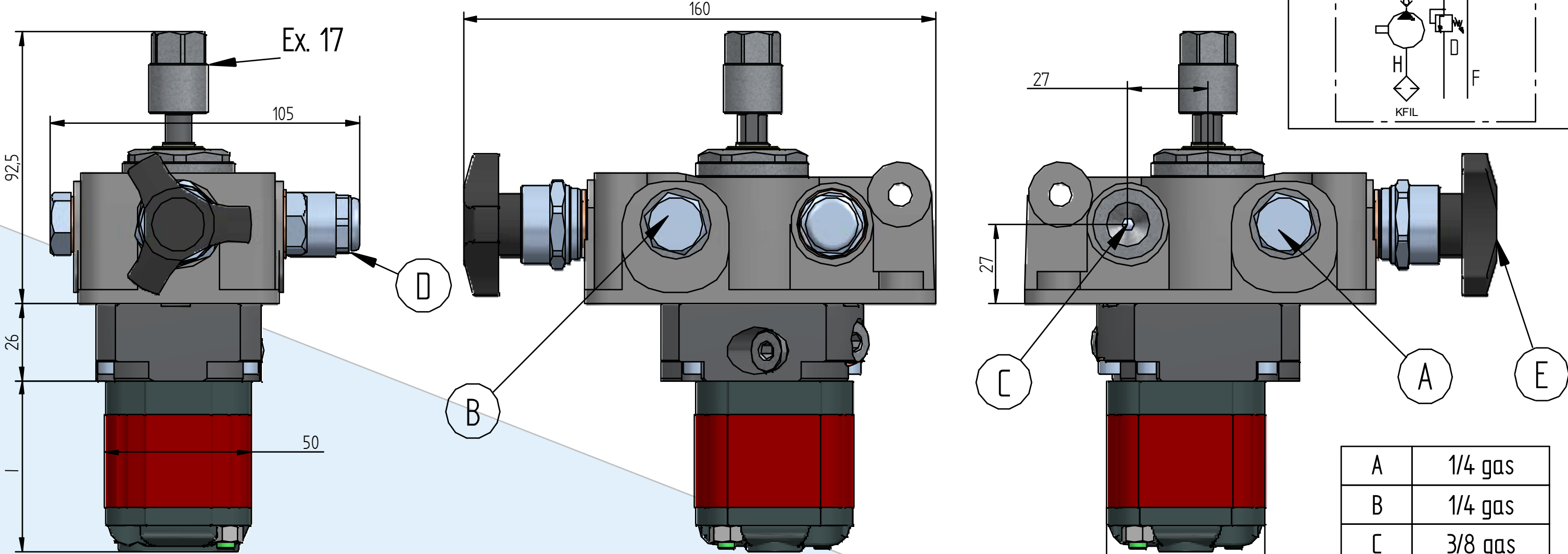
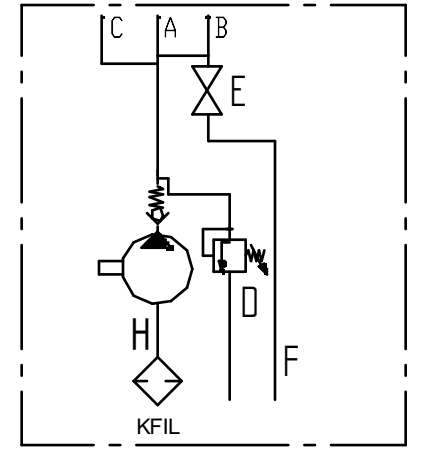

l: min 46,8 mm Max 63,5 mm

A	1/4 gas
B	1/4 gas
C	3/8 gas
D	Relief valve
F	Hole
H	1/4 gas

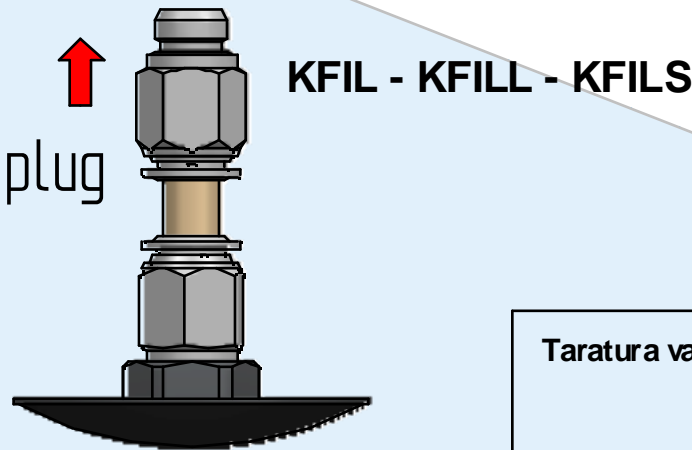

H Suction plug

Taratura valvola di massima pressione - Comunque non oltre la pressione massima della pompa.
Relief valve setting - However not over the pump's max pressure
min - max (bar) 30 - (...)

F Discharging hole

H Suction plug

Pompa ad ingranaggi - Gear pump

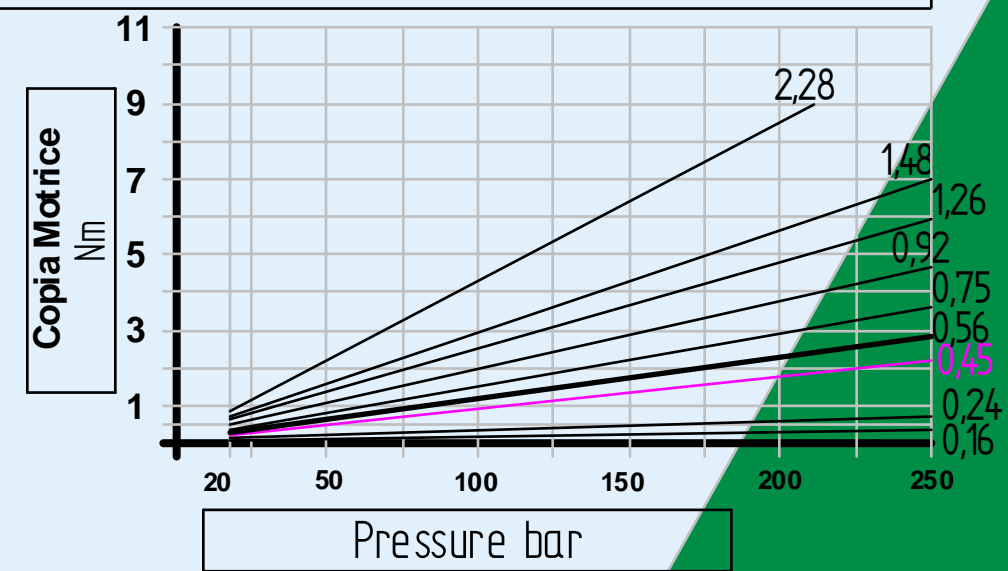
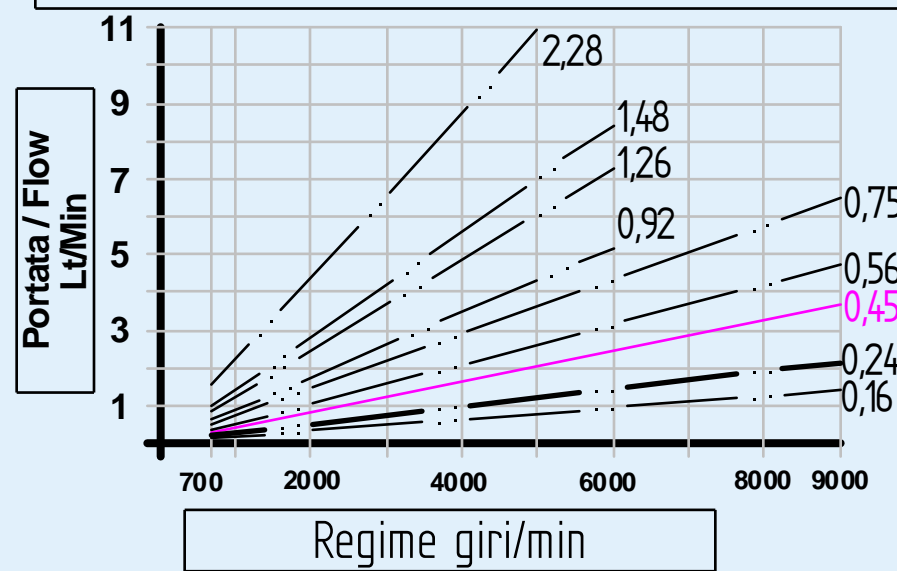

Codice di ordinazione - Ordering code

ZES	Option 1	017	SEB
		025	
		045	
		057	
		076	
		098	
		127	
		152	
		230	

Option 1 cc Gear pump

017	0,16 cc
025	0,24 cc
045	0,45 cc - Standard Version
057	0,56 cc
076	0,75 cc
098	0,92 cc
127	1,26 cc
152	1,48 cc
230	2,28 cc

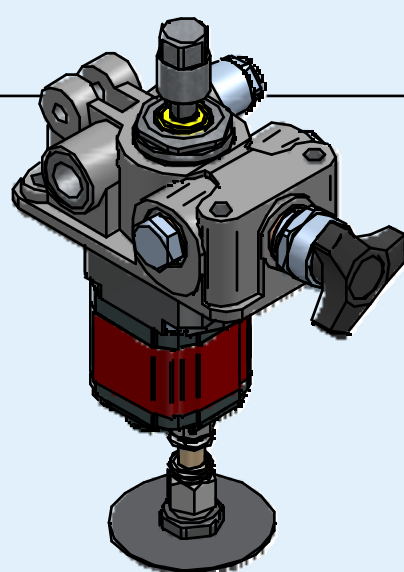

Type	Cilindrata Flow (cc)	Pressione massima Max pressure (bar)	rpm min.	rpm max.
017	0,16	260	700	9.000
025	0,24	260	700	9.000
045	0,45	280	700	9.000
057	0,56	280	700	9.000
076	0,75	280	700	9.000
098	0,92	280	700	6.000
127	1,26	280	700	6.000
152	1,48	280	700	6.000
230	2,28	210	700	5.000
Peso/Weight		3,3 kg		

KFIL - KFILL - KFILS
Filtro per aspirazione ordinabile separatamente
Suction filter can be ordered separately

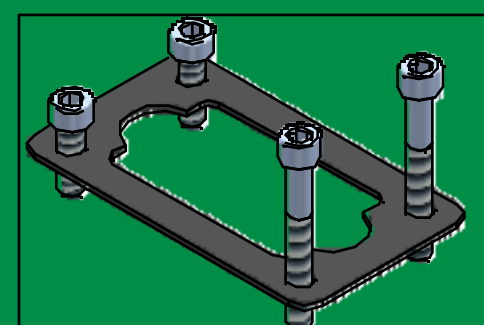

Kit di montaggio al serbatoio -
Mounting kit to oil tank